



CAST 'Y' TYPE STRAINER



GAMA ENGINEERING WORKS

OUR QUALITY BUILDS CUSTOMERS CONFIDENCE & RELATIONS.

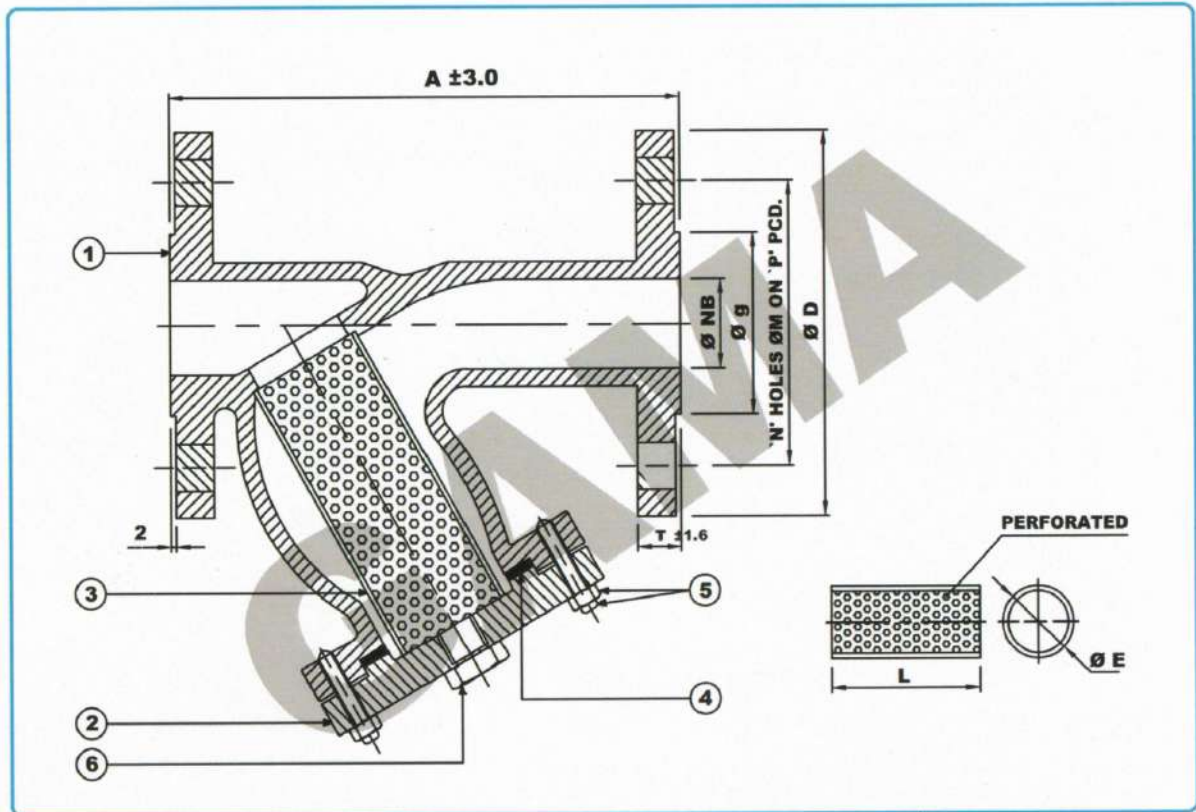

SIZE	Ø NB	A	Ø D	Ø g	T	P'	Ø M	N'	Ø E	L
1/2"	12.5	128	90	35	9.6	60	16	4	20	60
1"	25	160	110	51	12.7	80	16	4	33	80
1 1/2"	40	200	125	73	16	99	16	4	45	95
2"	50	230	150	92	18	121	19	4	58	120
2 1/2"	65	223	180	105	21	140	19	4	68	140
3"	80	242	190	127	22	152	19	4	80	140
4"	100	295	230	157	22	191	19	8	105	180
6"	150	405	280	216	24	241	22	8	155	250
8"	200	495	345	270	27	298	22	8	211	300
10"	250	622	405	324	30	362	25	12	265	410

SR. NO.	QTY.	DESCRIPTION	MATERIAL
1	1	BODY	C.S. / CF 8 / CF 8M / CF 3 / CF 3M
2	1	COVER	C.S. / CF 8 / CF 8M / CF 3 / CF 3M
3	1	SCREEN	S.S. 304 / 316 (20 / 30 / 40 / 60 / 80 / 100 MESH)
4	1	GASKET	S.S. 304 / 316 SPIRAL WOUND + GRAPHITE FILLER
5	AS REQ.	STUD & NUT	M.S. / B7 & 2H / B8 & 8M
6	1	DRAIN PLUG	M.S. / S.S. 304 / S.S. 316 (IF REQUIRED)

TEST PRESSURE - Kg / Cm²	
TESTING	BODY
HYDRAULIC	30

TECHNICAL DATA :	
Face to Face	Mfg. Std.
End Connection	Flanged Ends to ASME B 16.5 150#
Inspection & Testing Std.	API 598 / BS 5146



GAMA ENGINEERING WORKS

OUR QUALITY BUILDS CUSTOMERS CONFIDENCE & RELATIONS.
AN ISO 9001:2015 Certified Company.

49/98, Ashokpura, O/s. Shahpur Gate, Dudheshwar Road, Ahmedabad-380004.

Ph. (0) 079 - 25622479 | Web : www.gewvalves.com | E-mail : sales.gewvalves@gmail.com

'Y' TYPE FLANGED END STRAINER Size 15mm to 300mm CLASS : 150 & 300



NOTES: 1.) OTHER MATERIAL LIKE ASTM A 351 Gr. CF 3/CF 3M, HASTEALLOY 'C', (DUPLEX SS)ASTM A 890 Gr. 4A,5A,6A ARE ALSO AVAILABLE.
 2.) DEVELOPMENT IS CONTINUE, HENCE SPECIFICATION ARE SUBJECT TO CHANGE AT ANY TIME WITHOUT NOTICE.